

HINO 268

A

4 x 2 CONVENTIONAL
GVW 25,950 lbs. BBC 108"
ENGINE MODEL J08E-TA
(Turbo Intercooled)

DIMENSIONS (On standard specification)

Production code		NJ8JPSA	NJ8JRSA	NJ8JTSA	NJ8JVSA
Wheelbase code		P	R	T	V
Wheelbase	A in.	217.0	235.0	253.0	271.0
Overall length	B in.	354.6	372.6	390.6	390.6
Overall width	C in.	96.5	96.5	96.5	96.5
Overall height	D in.	106.9	106.9	106.9	106.9
Cab to axle	E in.	149.6	167.6	185.6	203.6
Rear overhang	F in.	97.0	97.0	97.0	79.0
Frame height at					
Front axle	G in.	37.0	37.0	37.0	37.0
Rear axle	H in.	39.8	39.8	39.8	39.8
Road clearance (at diff.axle)	J in.	11.2	11.2	11.2	11.2
Tread					
Front	K in.	79.3	79.3	79.3	79.3
Rear	L in.	72.2	72.2	72.2	72.2
Cab height	in.	69.0	69.0	69.0	69.0
Turning radius 180°					
Tire	in.	692.1	744.9	796.8	849.6
Wall to wall	in.	733.1	785.8	837.8	890.6

CHASSIS WEIGHTS (On std. spec.)

Total weight	MT lb.	9,965	10,009	10,064	10,165
Front axle	MT lb.	6,184	6,250	6,305	6,385
Rear axle	MT lb.	3,781	3,759	3,759	3,780
Total weight	AT lb.	9,899	9,943	10,009	10,100
Front axle	AT lb.	6,118	6,184	6,250	6,320
Rear axle	AT lb.	3,781	3,759	3,359	3,780

POWER LINE & PERFORMANCE 25,950 lbs. GVW

11.00R22.5-14 tires. (Option ratio is combined with 255/80R22.5 tire.)

Power line	Manual		Automatic	
	STD.	OPT.	OPT.	OPT.
Max. speed mph	76	78	78	79
Transmission Model	Eaton F55406A		Allison 2200RDS	
Type	Six-speed Direct drive synchromesh 1st-6th		Five-speed automatic	
Ratios	1st.	9.010	3.102	
	2nd.	5.270	1.811	
	3rd.	3.220	1.406	
	4th.	2.040	1.000	
	5th.	1.360	0.712	
	6th.	1.000	-	
Rev.	8.630	4.492		
Rear axle gear ratios	4.110	3.730	5.570	5.130

ENGINE

Model	HINO J08E-TA - 2004 EPA Certified
Type	Diesel 4-cycle, 6-cylinder in-line, water-cooled
Combustion system	Direct injection type
Max. output (SAE Gross)	220HP at 2,500 rpm
Max. torque (SAE Gross)	520 lb.-ft. at 1,500 rpm
Bore and stroke	4.41 x 5.12 in.
Piston displacement	8 L
Fuel injection pump	Radial plunger pump (HP-4)
Governor	Electronically controlled
Intake system	Turbocharged and intercooled
Air cleaner	Paper filter type ("DONALDSON")
Fan clutch	Bimetal thermostat sensor, regulates fan speed

HINO  **TRUCKS**™

A TOYOTA Group Company

WWW.HINO.COM [T]248.648 6400

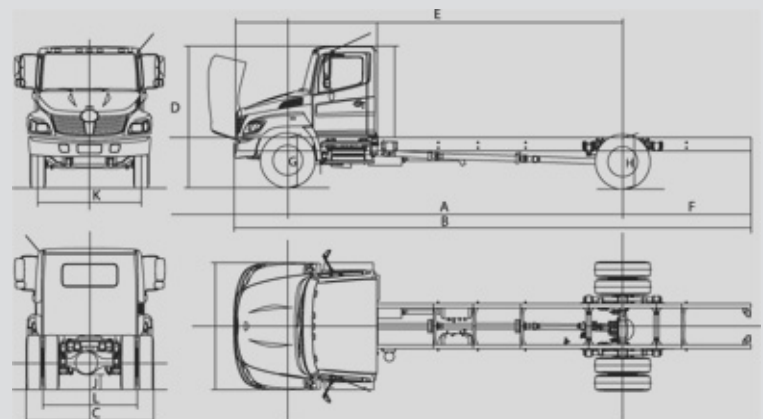

SEE THE 268A IN ACTION AT WWW.HINO.COM

HINO 268

A 4 x 2 CONVENTIONAL, GVW 25,950 lbs. BBC 108"
ENGINE MODEL J08E-TA (Turbo Intercooled) Spec. No. SS-NJ007

WEIGHT CAPACITIES

Front axle	lbs.	10,000
Rear axle	lbs.	19,000
Front spring	lbs.	12,000
Rear spring	lbs.	19,000

LIQUID CAPACITIES

Fuel tank	gal./US	52
Cooling system	gal./US	5.68 : Eaton FS5406 5.55 : Allison 2200RDS

AXLE / SUSPENSION

Front axle	MFS-10 series reversed Elliot, "I" beam
Front spring	Taper-leaf springs shock absorbers
Rear axle	RS19-145 series full-floating, single reduction single-speed by hypoid gears
Rear spring	Semi-elliptic main and auxiliary helper-leaf spring

FRAME

Ladder type	Straight C channel
Width	in. 34
Yield strength	PSI 80,000
Resisting bending moment (one side)	in_lbs. no reinforcement

STEERING

Type	Telescopic and tilt steering column, TRW-TAS65
------	--

BRAKES

Service brake	Full air, dual circuit, "S" cam type, leading & trailing shoes, with automatic adjustment
Disc diameter x lining width x thickness in.	Front; 15 x 4 x 0.73 Rear; 16.5 x 7 x 0.85
Control	Full air dual circuit with Antilock Brake System (ABS)
Parking brake	Spring brake acting on rear wheels
Air dryer for air tank	Equipped

WHEELS / TIRES

6 Wheels (Steel)	22.5X8.25 10-stud disc.
6 Tires	11R22.5(G) - Bridgestone R250F/M726

CLUTCH

Type	Dry single plate with damper springs EATON-SPICER SAS1401 series
Facing material	Cerametallic
Facing outside diameter in.	13.80
Control	Hydraulic

CHASSIS EQUIPMENT

Fuel pre-filter	Pre-filter (dust) and sedimenter (water)
Reflectors	Two rear, two front side
Hook	One at front

DASH INSTRUMENTATION

Meters and gauges	ft. lb. system
Speedometer	mph (km/h)
Odometer	(mile)
Fuel gauge	
Coolant temperature gauge	
Engine tachometer	
Air pressure gauge	
Warning and buzzers	
Oil pressure warning lamp and buzzer	
Air pressure level warning lamp and buzzer	
Coolant level warning lamp and buzzer	
Battery charging warning lamp	
High beam indicator lamp	
Turn signal pilot lamp	
Parking brake warning lamp	
Engine control system warning lamp	
ABS warning lamp	

CAB EQUIPMENT

Cab construction	All steel welded
Seating	Three man
Driver's seat	Adjustable, reclining, vinyl covered seat, air suspension
Passenger's seat	Bench type, vinyl, 2 passenger
Seat belts	3-point type (driver and passenger), one 2-point type (center)
Air conditioner	Denso 134
Heater/Defroster	18,357 BTU/h
Mirrors outside rearview	Four, 1 flat and 1 convex at each side
Sun visors	Two
Windshield	Laminated
Windshield wipers	Dual electric, 2-speed and intermittent
Over-head console	Two
Cruise control	Equipped

ELECTRICAL EQUIPMENT

Batteries	Two, parallel connection, each 12 V
Capacity	1200 CCA
Alternator	12 V, 100 A, brush (Delco)
Starter	12 V, 4.8 kW
Audio	AM/FM radio with CD player
Headlamps	Integrated with turn signal and hazard lamp
Daytime running lamps	
Stop/Tail lamps	
Back-up lamps	
Dome lamp	
Front side marker lamps	
Clearance lamps (front)	

Options

_Cold weather package (Block heater, heated mirror, glow plugs, heated pre-filter/sedimenter and heated air drier)
_Cloth seats
_Single passenger's seat - Adjustable reclining
_Clutch control with auto adjuster (1401 SOLO)
_Twin plate clutch (1402)
_Twin plate clutch control, auto adjuster (1402)
_Alternator - 12 V, 105 A, brushless (Denso)
_Dual fuel tank; 52 Gal x 2
_Fuel tank; 95 Gal
_Fuel filter; Davco
_Rear spring; with stabilizer
_Rear spring; with dual acting shock absorbers
_21,000 lb Hendrickson rear air suspension
_Tire size; 255/80R22.5
_4 inch extended, front bumper (black)
_3 piece, front bumper
_4 inch extended, 3 piece, front bumper (black)
_Power windows
_Battery GR31
_Battery GR27 x 3
_Battery GR31 x 2
_Engine block heater
_Heated mirrors

NOTE : All specifications of the products are within normal manufacturing allowances and tolerances. HINO MOTORS SALES U.S.A., INC. reserves the right to alter specifications at any time without previous notice. Some optional items of equipment may require extra time due to the need for their adaptation on the product line.

